

ALUMINUM SOFT JAWS

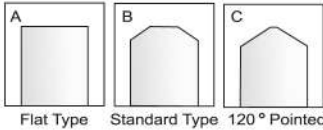

Flat Type Standard Type 120° Pointed

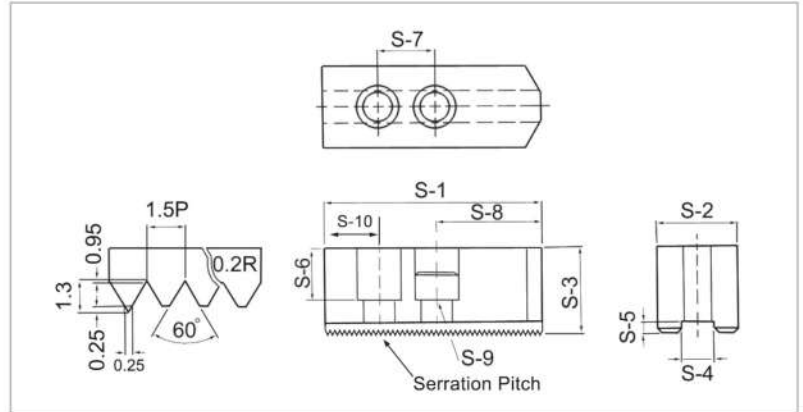

■ For other angle and dimensions, please find page13.

DIMENSIONS

UNIT: mm

DIMENSION ORDER NUMBER	S-1	S-2	S-3	S-4	S-5	S-6	S-7	S-8	S-9	S-10	Serration Pitch	Excursus
SJ-A04023C	51	23	23	10	4	13	14	27	M8	10	1.5x60°	
SJ-A05027C	62	23	27	10	4	17	14	38	M8	10	1.5x60°	
SJ-A06030B	73	31	31	12	5	19	20	38	M10	15	1.5x60°	
SJ-A08037B	95	35	37	14	5	22	25	46	M12	24	1.5x60°	
SJ-A10042B	110	40	42	16	5	27	30	50	M12	30	1.5x60°	
SJ-A12048B	129	48	48	21(18)	5	28	30	60	M16(M14)	39	1.5x60°	
SJ-A15062A	165	62	62	22(25.5)	8	37	43	85	M20	37	1.5x60°	
SJ-A18062A	165	62	62	22(25.5)	8	37	43	85	M20	37	1.5x60°	

- Material: Aluminum (6061 T6)
- To suit kitagawa and other famous chucks.

SPECIAL L TYPE

FEATURE

- ▶ We offer this special L type of soft jaws to save customers' time, **TAIKI**-Jaws in special design.
- ▶ Designed according to your workpiece.
- ▶ Every year we design and manufacture thousands of sets of jaws for customers.
- ▶ All designed to offer safe and profitable workholding.



Fig.1



Fig.2



Fig.3

■ Material: Steel (S45C)