

# EXTRA-LENGTH TYPE

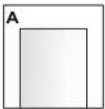
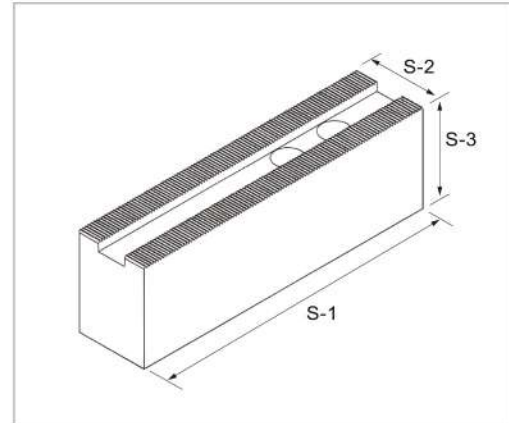

Flat Type

■ Flat Type only

## ▶ FEATURE

- ▶ Soft Jaws of extra-Length type are suitable for parts with bigger outer dia.
- ▶ For example : Outer dia.250mm will suit to use SJ08 with extra-Length 150mm of soft jaws.

## ▶ DIMENSIONS

UNIT: mm

### SJ08

<i>DIMENSION</i>	Length	Width	Height	Serration	Excursus
<i>ORDER NUMBER</i>	S-1	S-2	S-3	Pitch	
<b>SJ08048150A</b>	150	35	48	1.5x60°	
<b>SJ08063150A</b>	150	35	63	1.5x60°	

### SJ12

<i>DIMENSION</i>	Length	Width	Height	Serration	Excursus
<i>ORDER NUMBER</i>	S-1	S-2	S-3	Pitch	
<b>SJ12048150A</b>	150	48	48	1.5x60°	
<b>SJ12048170A</b>	170	48	48	1.5x60°	
<b>SJ12060170A</b>	170	48	60	1.5x60°	
<b>SJ12060200A</b>	200	48	60	1.5x60°	
<b>SJ12080170A</b>	170	48	80	1.5x60°	

### SJ10

<i>DIMENSION</i>	Length	Width	Height	Serration	Excursus
<i>ORDER NUMBER</i>	S-1	S-2	S-3	Pitch	
<b>SJ10048150A</b>	150	40	48	1.5x60°	
<b>SJ10063150A</b>	150	40	63	1.5x60°	
<b>SJ10083150A</b>	150	40	83	1.5x60°	
<b>SJ10090180A</b>	180	40	90	1.5x60°	

### SJ15

<i>DIMENSION</i>	Length	Width	Height	Serration	Excursus
<i>ORDER NUMBER</i>	S-1	S-2	S-3	Pitch	
<b>SJ15072200A</b>	200	62	72	1.5x60°	
<b>SJ15072250A</b>	250	62	72	1.5x60°	

- Material : Steel (S45C)
- Serration Pitch:1.5mmX60°
- To suit kitagawa and other famous chucks.