

EXTRA-HEIGHT TYPE

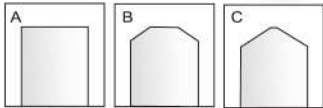
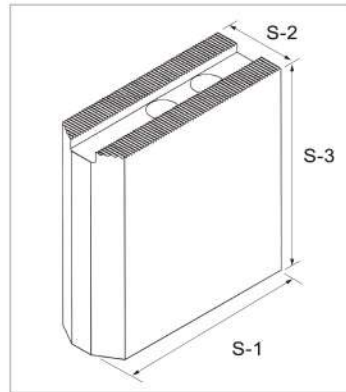

A Flat Type B Standard Type C 120° Pointed

- With above angle for different workpiece:
- For Flat Type Jaws, please add "A" to suffix of order number, such as: SJ08060A, Standard Type: SJ08060B, 120° Pointed : SJ08060C.

FEATURE

- Soft jaws of extra-height type are suitable for the length of workpiece is longer, such as 100mm length will need soft jaws of extra-height type with over 70mm height which will increase the accuracy and stability of production process.
- We are available from over 8 inch which over 200mm height.

DIMENSIONS

UNIT: mm

SJ05

ORDER NUMBER	Length S-1	Width S-2	Height S-3	Serration Pitch	Excursus
SJ05036	62	23	36	1.5x60°	
SJ05048	62	23	48	1.5x60°	
SJ05070	62	23	70	1.5x60°	
SJ05100	62	23	100	1.5x60°	

SJ06

ORDER NUMBER	Length S-1	Width S-2	Height S-3	Serration Pitch	Excursus
SJ06036	73	31	36	1.5x60°	
SJ06050	73	31	50	1.5x60°	
SJ06060	73	31	60	1.5x60°	
SJ06070	73	31	70	1.5x60°	
SJ06080	73	31	80	1.5x60°	
SJ06090	73	31	90	1.5x60°	
SJ06100	73	31	100	1.5x60°	
SJ06130	73	31	130	1.5x60°	
SJ06150	73	31	150	1.5x60°	

SJ08

ORDER NUMBER	Length S-1	Width S-2	Height S-3	Serration Pitch	Excursus
SJ08050	95	35	50	1.5x60°	
SJ08060	95	35	60	1.5x60°	
SJ08070	95	35	70	1.5x60°	
SJ08080	95	35	80	1.5x60°	
SJ08090	95	35	90	1.5x60°	
SJ08100	95	35	100	1.5x60°	
SJ08120	95	35	120	1.5x60°	
SJ08150	95	35	150	1.5x60°	
SJ08180	95	35	180	1.5x60°	
SJ08210	95	35	210	1.5x60°	

- Material: Steel (S45C)
- Serration Pitch: 1.5mmX60°
- To suit kitagawa and other famous chucks.

SJ10

ORDER NUMBER	Length S-1	Width S-2	Height S-3	Serration Pitch	Excursus
SJ10050	110	40	50	1.5x60°	
SJ10060	110	40	60	1.5x60°	
SJ10070	110	40	70	1.5x60°	
SJ10080	110	40	80	1.5x60°	
SJ10090	110	40	90	1.5x60°	
SJ10100	110	40	100	1.5x60°	
SJ10120	110	40	120	1.5x60°	
SJ10150	110	40	150	1.5x60°	
SJ10180	110	40	180	1.5x60°	
SJ10200	110	40	200	1.5x60°	

SJ12

ORDER NUMBER	Length S-1	Width S-2	Height S-3	Serration Pitch	Excursus
SJ12060	129	48	60	1.5x60°	
SJ12080	129	48	80	1.5x60°	
SJ12100	129	48	100	1.5x60°	
SJ12120	129	48	120	1.5x60°	
SJ12150	129	48	150	1.5x60°	
SJ12180	129	48	180	1.5x60°	
SJ12200	129	48	200	1.5x60°	

SJ15 / SJ18

ORDER NUMBER	Length S-1	Width S-2	Height S-3	Serration Pitch	Excursus
SJ15080A	165	62	80	1.5x60°	
SJ15100A	165	62	100	1.5x60°	
SJ15130A	165	62	130	1.5x60°	
SJ15150A	165	62	150	1.5x60°	
SJ15180A	165	62	180	1.5x60°	
SJ15220A	165	62	220	1.5x60°	