

SOFT JAWS FOR HYDRAULIC CHUCKS

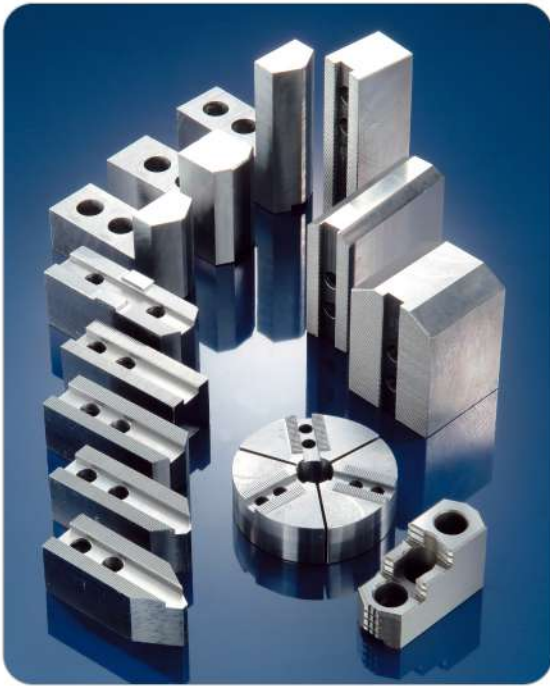

TAIKI has more than forty years of experience in manufacturing soft jaws. With everlasting efforts, TAIKI has been in a professional and leading position. We provide different styles and size to suit for all brands of hydraulic power chucks. We categorize the jaws into many types, such as standard, extra-height, extra-width and extra-length type. Varied specifications are provided in order to satisfy all customers' different demands to promote high efficiency and accuracy.

Welcome OEM customers to be our business partners. Please feel free to contact us for more details or information. (Please find page 13 & 14)

1.5mmX60° STANDARD TYPE

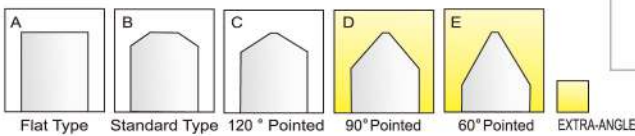
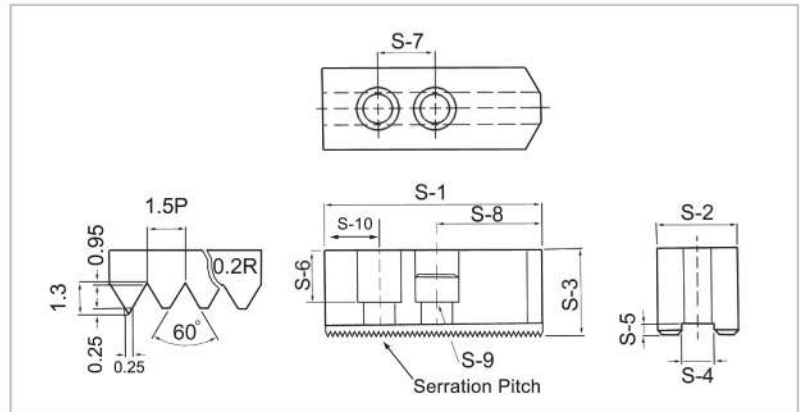

- With above angle for different workpiece:
- For Flat Type Jaws, please add "A" to suffix of order number, such as :SJ08037A
Standard Type :SJ08037B, 120° Pointed :SJ08037C, 90° Pointed :SJ08037D, 60° Pointed :SJ08037E,

▶ DIMENSIONS

UNIT: mm

DIMENSION ORDER NUMBER	S-1	S-2	S-3	S-4	S-5	S-6	S-7	S-8		S-9	S-10 (A/B angle)	S-10 (C/D/E angle)	Serration Pitch	Gross Weight (kg)
								A,B	C,D E					
SJ04023	51	23	23	10	4	13	14	27		M8		10	1.5x60°	0.5
SJ05027	62	23	27	10	4	17	14	38		M8		10	1.5x60°	0.7
SJ06030	73	31	31	12	5	19	20	38 43		M10	15	10	1.5x60°	1.5
SJ08037	95	35	37	14	5	22	25	46 54		M12	24	16	1.5x60°	2.5
SJ10042	110	40	42	16	5	27	30	50 60		M12	30	20	1.5x60°	3.6
SJ12048	129	48	48	21(18)	5	28	30	60 74		M16(M14)	39	25	1.5x60°	6.2
SJ15062A	165	62	62	22(25.5)	8	37	43	85		M20	37		1.5x60°	12.6
SJ18062A	165	62	62	22(25.5)	8	37	43	85		M20	37		1.5x60°	12.6

- Material: Steel (S45C)
- To suit kitagawa and other famous chucks.